

CLASSIFICADOR DE PENEIRAS PARA CEREAIS

SCREEN GRADER

BJNH





CARACTERÍSTICAS TÉCNICAS

TECHNIAL FEATURES

- Estrutura metálica robusta;
Robust metal structure;
- Baixo consumo de energia;
Low energy consumption;
- Sistema de fluxo contínuo;
Continuous flow system;
- Área mínima exigida para a instalação;
Minimum area required for installation;
- Indispensável nos processos de padronização que exigem máxima precisão na classificação dos cereais por tamanho;
Indispensable in separation processes that require maximum precision in the classification of cereals by size;

MODELO <i>Model</i>	CAPACIDADE <i>Capacity</i> (sacos/h) (bags/h)	POTÊNCIA <i>Power</i> (Motores Trif. 220/380 V) (Three-Phase Motors 220/380 V)	PESO <i>Weight</i>
BJNH	100 sacos/h 100 bags/h	2 HP	862 Kg

*OBS: Produção depende do peso específico do grão
*OBS: Production depends on the specific weight of the grain

BJNH

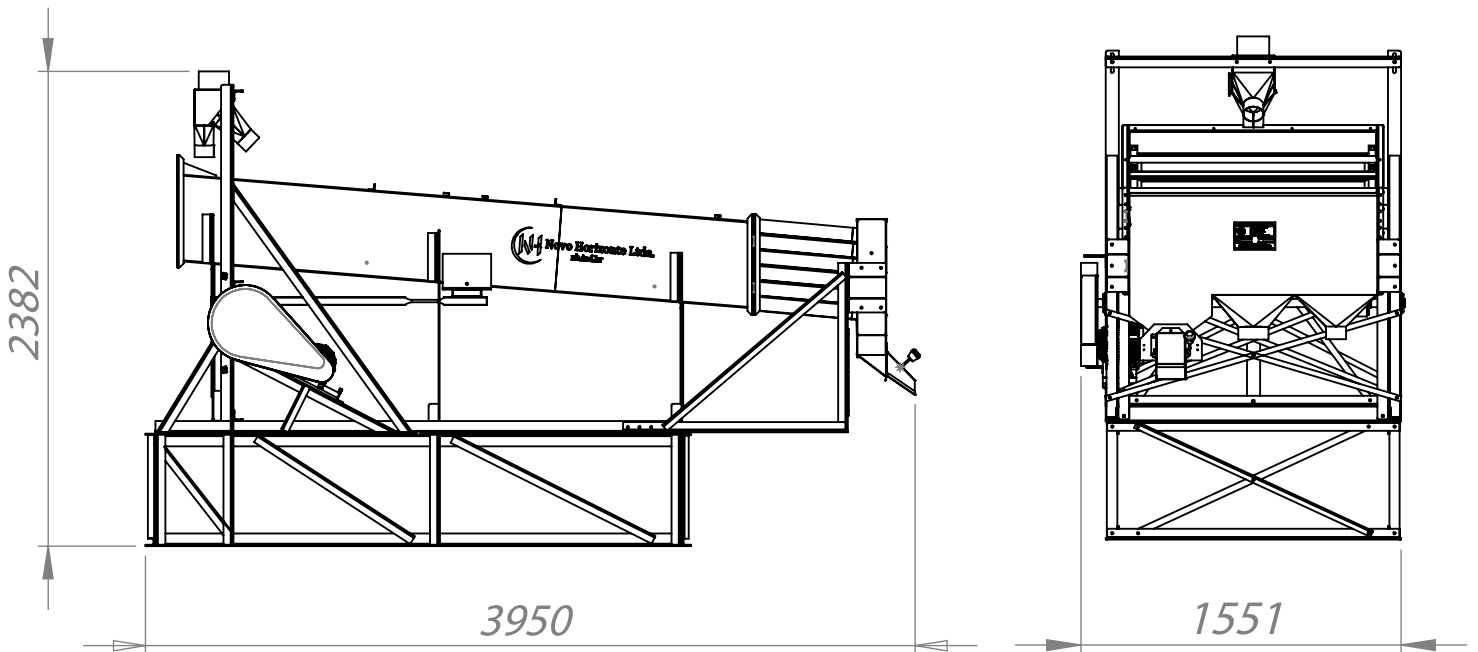

Aceitamos



Consulte-nos



Av. Dorival Faveri, 214 - Graminha
13481-604 - Limeira - SP
Fone: (19) 3451-2822
novo.horizonte@nh.ind.br

